

CHEMICAL REVIEWS

VOLUME 68, NUMBER 5 SEPTEMBER 26, 1968

OPTICAL ROTATORY DISPERSION AND CIRCULAR DICHROISM

HENRY EYRING, HAN-CHUNG LIU, AND DENNIS CALDWELL

Departments of Chemistry and Physics, University of Utah, Salt Lake City, Utah

Received January 8, 1968

CONTENTS

I. Introduction.....	525
II. Optical Rotatory Dispersion (ORD) and Circular Dichroism (CD).....	525
III. Quantum Theory of Optical Rotation.....	527
IV. Optical Rotation as Mixing of Pure States.....	529
V. The One-Electron Model.....	529
VI. Kirkwood's Coupled Oscillator Model.....	530
VII. Helical Sense, Helical Content, and Moffitt's Constant.....	532
VIII. The Interactions Responsible for Optical Rotation.....	535

I. INTRODUCTION

The phenomena of circular birefringence and dichroism are well understood. In the last decade rapid progress in this field is exemplified by the experimental study of steroids by Djerassi.¹ Since then several theoretical studies²⁻⁶ have contributed to the understanding of the molecular origin. The purpose of this review is to treat the theory of optical rotation from a unified point of view to examine the ideas which have been advanced, and to consider the structural information derivable from these studies. A list of the books and the review articles on this field is given.^{1,7-14}

II. OPTICAL ROTATORY DISPERSION (ORD) AND CIRCULAR DICHROISM (CD)

There are some substances for which the plane of polarization of transmitted linearly polarized light

will be rotated. These substances are said to be optically active. The phenomenon was discovered by Arago¹⁵ for quartz (solid) in 1811 and by Biot¹⁶ for liquid in 1815, and is commonly called optical rotation. In optical rotation measurements the term plane of polarization is meant to mean the plane determined by the electric vector and the direction of propagation (see Figure 1). The plane perpendicular to the direction of propagation, over which the vectors \vec{E} and H are constant, is sometimes also described as a plane of polarization. In our discussion the first definition will be used. The convention is that a clockwise rotation for an observer facing the oncoming wave is called dextrorotatory; a counterclockwise rotation is levorotatory (Figure 2).

Fresnel¹⁷ was the first to ascribe rotation of plane-polarized light to the different velocities of transmission of the two circularly polarized beams whose amplitudes add to form plane-polarized light. The phase difference set up in the medium by the light is equivalent to a rotation of the plane of polarization. The \vec{E} vector of the light is

$$\vec{E} = Re\vec{E}_0e^{i\psi} \quad (1)$$

Here $\psi = 2\pi\nu[t - (n/c)z]$ is the phase angle. Since the rotation, α , is half the change in phase angle per centimeter of right and left circularly polarized light, we write

(1) C. Djerassi, "Optical Rotatory Dispersion," McGraw-Hill Book Co., Inc., New York, N. Y., 1960.

(2) W. Moffitt, *J. Chem. Phys.*, **25**, 467 (1956).

(3) W. Moffitt, D. D. Fitts, and J. G. Kirkwood, *Proc. Natl. Acad. Sci. U. S.*, **43**, 723 (1957).

(4) W. Moffitt, *J. Chem. Phys.*, **25**, 1189 (1956).

(5) W. Moffitt, R. B. Woodward, A. Moscovitz, W. Klyne, and C. Djerassi, *J. Am. Chem. Soc.*, **83**, 4013 (1961).

(6) W. Moffitt and A. Moscovitz, *J. Chem. Phys.*, **30**, 648 (1959).

(7) T. M. Lowry, "Optical Rotatory Powder," Longmans, Green and Co., Ltd., London, 1935.

(8) P. Crabbé, "Optical Rotatory Dispersion and Circular Dichroism in Organic Chemistry," Holden-Day, Inc., San Francisco, Calif., 1965.

(9) L. Velluz, M. Legrand, and M. Grosjean, "Optical Circular Dichroism," Academic Press Inc., New York, N. Y., 1965.

(10) B. H. Levedahl and T. W. James, *Tetrahedron*, **13**, No. 1-3 (1961).

(11) "A Discussion on Circular Dichroism: Electronic and Structure Principles," Vol. A297, No. 1448, Proceedings of the Royal Society, London, 1967, pp 2-172.

(12) W. Kauzman, J. Walter, and H. Eyring, *Chem. Rev.*, **26-27**, 339 (1940).

(13) *Advan. Chem. Phys.*, **4**, 67, 113 (1962).

(14) S. F. Mason, *Quart. Rev.* (London), **17**, 20 (1963).

(15) T. Arago, *Mém. Inst.*, **12**, 93, 115 (1811).

(16) J. B. Biot, *Mém. Acad. Sci.*, **2**, 41 (1817).

(17) A. Fresnel, *Ann. Chim. Phys.*, **28**, 147 (1825).

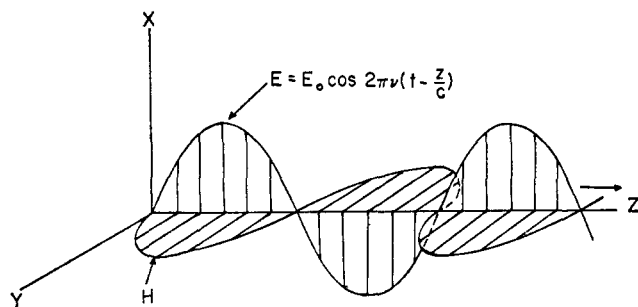

Figure 1.—The field vectors in an electromagnetic wave.

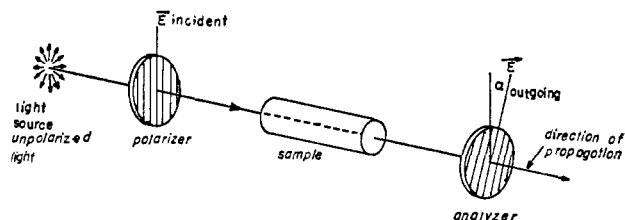

Figure 2.—The measurement of the angle of rotation.

$$\alpha = \frac{\pi}{\lambda}(n_l - n_r) \quad (2)$$

where α is in radians per unit length and λ is the wavelength of the incident light.

Molecular rotation is defined as the rotation in degrees per decimeter divided by the concentration, c , in grams per cubic centimeter multiplied by $1/100$ th of the molecular weight, MW.

$$[\phi] = \frac{18MW}{\lambda c}(n_l - n_r) \quad (3)$$

This equation implies that the rotation depends linearly on both path length and concentration, which will be true in the limit of low concentrations. At high concentrations molecular interactions cause deviations from linearity.

The rotation, like the refractive index, also depends on the frequency of the incident light. The wavelength dependence of molecular rotation is called optical rotatory dispersion (ORD). An ORD curve across an electronic absorption band is S-shaped while the curve for circular dichroism is Gaussian. This behavior is called the Cotton effect. A Cotton effect with its peak on the long-wavelength side is conventionally assigned as positive. In the region of absorption the two components of light are also absorbed differently by the optically active medium so that the emergent light is elliptically polarized. This phenomenon is called circular dichroism (CD) (Figure 3).

The imaginary part of the refractive index, \hat{n} , is related to the absorption.

$$\psi = 2\pi\nu\left(t - \frac{\hat{n}}{c}z\right)$$

$$\hat{n} = n - ik$$

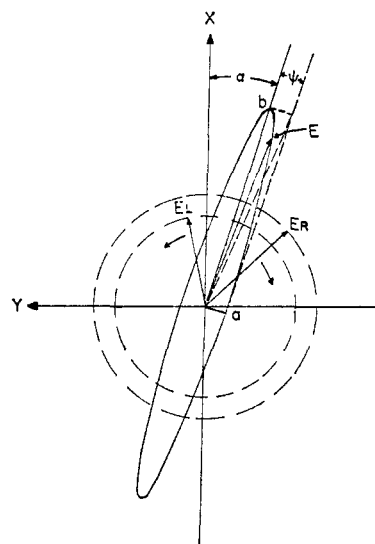

Figure 3.—Elliptically polarized light.

The attenuation of the electric vector is thus $\exp(-2\pi\nu kz/c)$. The intensity, which is proportional to the absolute square of the electric vector, is attenuated by $\exp(-4\pi\nu kz/c)$. The ellipticity, Ψ , is defined by the equation

$$\tan \Psi = \frac{E_r - E_l}{E_r + E_l} = \tanh \frac{\pi}{\lambda}(k_l - k_r)d \quad (4)$$

For small absorption $\tan \Psi$ is proportional to Ψ thus

$$\Psi = \frac{\pi}{\lambda}(k_l - k_r) \quad (5)$$

The definition of molecular ellipticity, $[\theta]$, parallels that of rotation. Thus we have

$$[\theta] = \frac{MW}{100} \frac{1}{c} \frac{\pi}{\lambda}(k_l - k_r) \frac{180}{\pi} \times 10 \text{ deg/dm} \quad (6)$$

Ordinary absorption follows Beer's exponential law¹⁸

$$I = I_0 \times 10^{-A} \quad (7)$$

where A is the absorbance and is related to the extinction coefficient, ϵ , by the equation

$$\epsilon = \frac{A}{d \text{ (cm)} \times c' \text{ (moles/l.)}} \quad (8)$$

where d is distance in centimeters and c' is concentration in moles per liter.

The relation between k and ϵ is

$$I = I_0 \times 10^{-A} = I_0 \times 10^{-\epsilon dc'} = I_0 e^{-4\pi kd/\lambda}$$

$$k = \frac{\lambda}{4\pi d} (\ln 10) \epsilon dc' = 2.303 \frac{\lambda c'}{4\pi} \epsilon$$

Therefore molecular ellipticity becomes

$$[\theta] = 3300(\epsilon_l - \epsilon_r) \quad (9)$$

(18) F. Woldbye and S. Bagger, *Acta Chem. Scand.*, **20**, 1145 (1966).

This is a linear relation between the molecular ellipticity $[\theta]$ and the difference in the extinction coefficients.

$$\Delta\epsilon \equiv \epsilon_l - \epsilon_r \quad (10)$$

The differential extinction coefficient varies by several orders of magnitude and is widely used.

A plot of circular dichroism against wavelength gives the wavelength dependence of the differential extinction coefficient and has a Gaussian shape. The circular dichroism, $[\theta]$, can have either sign, while the ordinary absorption coefficient is invariably positive.

ORD and CD curves are related. Both contain the same kind of information and are due to the same electronic transition. Their relation is formally expressed by the reciprocal Kramers-Kronig¹⁹ relation.

$$\phi(\lambda) = \frac{2}{\pi} \int_0^{\infty} \theta(\lambda') \frac{\lambda'}{\lambda^2 - \lambda'^2} d\lambda' \quad (11)$$

$$\theta(\lambda) = -\frac{2}{\pi\lambda} \int_0^{\infty} \phi(\lambda') \frac{\lambda'^2}{\lambda^2 - \lambda'^2} d\lambda' \quad (12)$$

In principle the complete knowledge of one determines the other.

The combined use of ORD and CD with ordinary ultraviolet absorption spectra is very powerful in spectroscopic and structural studies of molecules. ORD is simpler in experiment and in principle involves crossed polarizers. The difficulties in making CD measurement have only been overcome recently.²⁰

CD is much more powerful in resolving overlapping absorption bands (see Figure 4). This arises from the fact that the CD curve is confined to a small region in which the optically active medium absorbs, while the tail of ORD curve extends outside the region of absorption. Many optically active media show neighboring CD bands having opposite signs.

For media with absorption bands only in the region below the far-uv, ORD measurement is very useful because their tails in the far-uv can be measured and studied.²¹ The earlier D-line ORD data usually give small rotations and are well outside the regions of absorption.

The electronic origin of ORD, CD, and absorption spectra is well understood. The vibration and rotational aspects are usually negligible in those studies. It is often possible to consider rotation or dichroism due to a single electron or a single chemical group. The idea of partial rotation and dichroism greatly simplifies the theoretical considerations.

III. QUANTUM THEORY OF OPTICAL ROTATION

Rosenfeld²² first gave a quantum mechanical theory of optical rotation for spectral regions well removed

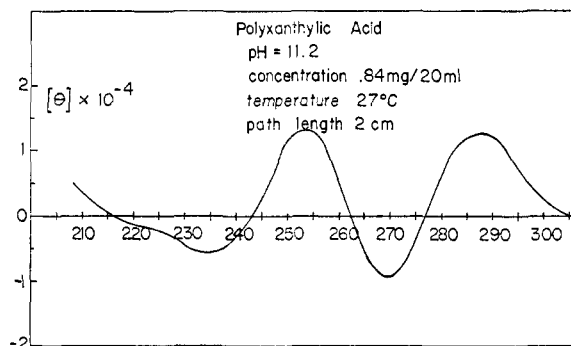

Figure 4.—The circular dichroism curve of polyxanthylic acid at pH 11.2, showing five discernible circular dichroism bands in the spectral region from 210 to 310 $m\mu$.

from the absorption maxima using a semiclassical treatment of the radiation field²³ and obtained the rotation in terms of the fundamental molecular quantity, the rotatory strength. The wavelength dependence is reminiscent of the many terms in Drude's equation, which has been used to correlate experimental data. Rosenfeld's equation is

$$[\phi]_{\lambda} = \frac{96\pi N n_{\lambda}^2 + 2}{hc} \sum_i \frac{\lambda_i^2 R_i}{\lambda^2 - \lambda_i^2} \quad (13)$$

where $[\phi]_{\lambda}$ is the molecular rotation for incident light of wavelength λ , N is Avogadro's number, h is Planck's constant, c is the velocity of light, n_{λ} is the index of refraction of the dispersive medium for incident light of wavelength λ , $(n_{\lambda}^2 + 2)/3$ is the Lorentz correction of the local field, and λ_i is the wavelength of the absorption maximum of the i th electronic transition. The quantity R_i is the rotatory strength for the i th electronic excitation. The rotatory strength is defined as the imaginary part of the scalar product of the molecular electric dipole moment with the magnetic dipole moment for the electronic transition under consideration. For a transition from the lower state Ψ_0 to the upper state Ψ_i , one has

$$R_i = \text{Im}(\psi_0 | \vec{p} | \psi_i) \cdot (\psi_i | \vec{m} | \psi_0) \quad (14)$$

It turns out that circular dichroism is also governed by the rotatory strength.²⁴ The rotatory strength R_i characterizes the i th electronic transition and fixes the sign and magnitude of the Cotton effect. The Rosenfeld equation has been derived for undamped motion and accordingly has a singularity at resonance, which can only be removed by the inclusion of damping terms. When the incident light is of the same wavelength as that of the absorption maximum, *i.e.*, $\lambda \approx \lambda_i$,

(21) K. Mislow, E. Bunnenberg, R. Records, K. Wellman, and C. Djerassi, *J. Am. Chem. Soc.*, **85**, 1342 (1963).

(22) L. Rosenfeld, *Z. Physik*, **52**, 161 (1928).

(23) E. V. Condon, *Rev. Mod. Phys.*, **9**, 432 (1937).

(24) E. V. Condon, W. Altar, and H. Eyring, *J. Chem. Phys.*, **5**, 753 (1937).

(19) Reference 1, Chapter 12, p 157.

(20) Reference 9, Chapter IV.

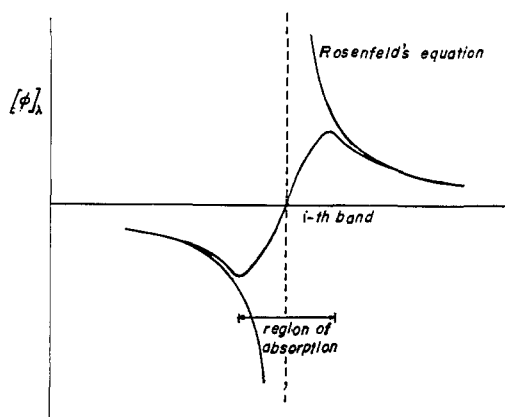

Figure 5.—Comparison of Rosenfeld's equation with actual behavior in the absorption region.

the molecular rotation according to the Rosenfeld equation goes to infinity, as shown in Figure 5.

The rotatory strength also reflects the stereochemical requirement for an optically active substance. It is a pseudo-scalar which changes sign on reflection and inversion in the origin. Many structural features of optically active molecules are reflected in the properties of the rotatory strength. Symmetry consideration alone yields much useful information.

The stereochemical rule specifies the kind of structural asymmetry required of an optically active molecule (Pasteur, 1866). Only molecules not superimposable on their mirror images are optically active. The two components of the nonsuperimposable mirror-image pair are called enantiomorphs. Molecules with either a plane of symmetry or a center of inversion are superimposable on their mirror images and are therefore optically inactive.

However, the nonsuperimposability of the mirror-image pair is a more general criterion. A plane of symmetry and a center of inversion are equivalent respectively to a onefold and a twofold rotation-reflection axis of symmetry. There are molecules which have a fourfold rotation-reflection axis of symmetry and which are superimposable on their mirror images and are therefore optically inactive.²⁵ The stereochemical rule implies that the mirror-image pair of a molecule shows opposite rotation. The racemate of a compound contains equal amounts of both enantiomorphs and is therefore optically inactive. Most biologically important molecules exist only in one configuration and are optically active. It is expected that ORD and CD are important in the structural studies of biological molecules. It is known now that the over-all symmetry property of a molecule determines its optical activity. The group-theoretical method is therefore widely used.

Paralleling Mulliken's oscillator strength²⁶ of absorption spectra, Moffitt and Moscovitz⁶ gave the following equation for the relation between the rotatory strength, R_i , and the experimental CD curve, $\theta_i(\lambda)$

$$R_i = \frac{3c\hbar}{4\pi^2 N_1} \int_i \frac{\theta_i(\lambda) d\lambda}{\lambda} \quad (15)$$

where $\theta_i(\lambda) = 1/4(k_1 - k_r)$. In terms of the molecular ellipticity, $[\theta_i(\lambda)]$ is thus

$$R_i = 0.696 \times 10^{-42} \int_i \frac{[\theta_i(\lambda)] d\lambda}{\lambda} \quad (16)$$

Using the relation $[\theta(\lambda)] = 3300\Delta\epsilon(\lambda)$, the rotatory strength is

$$R_i = 0.23 \times 10^{-38} \int_i \frac{\Delta\epsilon_i(\lambda) d\lambda}{\lambda} \quad (17)$$

This equation can be justified in the following way. From the Kramers-Kronig relation, the rotation and the ellipticity are related by²⁷

$$\begin{aligned} \phi(\nu) &= \frac{\pi\nu}{c}(n_1 - n_r) = \frac{2\nu^2}{\pi} \int_0^\infty \frac{\theta(\nu') d\nu'}{\nu'(\nu'^2 - \nu^2)} = \\ &= \frac{2\nu^2}{\pi} \int_0^\infty \frac{\theta(\nu')/\nu' d\nu'}{(\nu_0^2 - \nu^2) \left(1 + \frac{\nu'^2 - \nu_0^2}{\nu_0^2 - \nu^2}\right)} \end{aligned}$$

$\theta(\nu')$ is different from zero for ν' close to the absorption maximum ν_0 . When the frequency of the incident light is well removed from the natural frequency ν_0 of the optically active molecule, $|\nu'^2 - \nu_0^2| \ll |\nu_0^2 - \nu^2|$; therefore

$$\phi(\nu) \cong \frac{2\nu^2}{\pi(\nu_0^2 - \nu^2)} \int \frac{\theta(\nu) d\nu}{\nu}$$

Comparing this with the Rosenfeld equation and assuming that the rotations due to different transitions do not overlap, one finds

$$R_i = \frac{3\hbar c}{4\pi^2 N_1} \int_i \frac{\theta_i(\lambda) d\lambda}{\lambda}$$

The sign of the rotatory strength is useful in deducing structural information, but the order of magnitude also lends insight into the electronic origin of an optically active band.²⁸ The natural unit of rotatory strength is

$$ea_0 \frac{e\hbar}{2m_e c} = 2.35 \times 10^{-38}$$

where a_0 is the radius of the first Bohr orbit of the hydrogen atom. $e\hbar/2m_e c$ is the Bohr magneton.

(25) G. E. McCasland and S. Proskow, *J. Am. Chem. Soc.*, **78**, 5646 (1956).

(26) R. S. Mulliken, *J. Chem. Phys.*, **7**, 14 (1939).
 (27) C. A. Emeis, L. J. Oosterhoff, and G. de Vries, *Proc. Roy. Soc. (London)*, **A297**, 54 (1967).
 (28) A. Moscovitz, *ibid.*, **A297**, 16 (1967).

IV. OPTICAL ROTATION AS MIXING OF PURE STATES

A transition is optically active when it has a non-vanishing rotatory strength. For the transition from the ground-state $|a\rangle$ to the excited state $|b\rangle$, the rotatory strength is the imaginary part of the scalar product of the molecular electric dipole moment and the magnetic dipole moment for the transition. These moments are $\langle a|\vec{p}|b\rangle$ and $\langle b|\vec{m}|a\rangle$ so that

$$R_{a\rightarrow b} = \text{Im}\langle a|\vec{p}|b\rangle \cdot \langle b|\vec{m}|a\rangle \quad (18)$$

Equation 18 is an alternate way of writing eq 14. Both notations are common in the literature and should not cause confusion.

For molecules having a plane or center of symmetry there is no pair of states, $|a\rangle$ and $|b\rangle$, for which both $\langle a|\vec{p}|b\rangle$ and $\langle a|\vec{m}|b\rangle$ are different from zero. The electric dipole moment $\langle a|\vec{p}|b\rangle$ is different from zero for pairs of states which are both even or both odd while the magnetic dipole $\langle a|\vec{m}|b\rangle$ is different from zero for pairs of states with one even and the other odd. According to the selection rule for a system with spherical symmetry, a transition is purely electrically allowed if $\Delta n = \text{any number}$, $\Delta l = \pm 1$, and $\Delta m = 0, \pm 1$, in which case $\langle a|\vec{p}|b\rangle \neq 0$ and $\langle a|\vec{m}|b\rangle = 0$. It is purely magnetically allowed if $\Delta n = 0$, $\Delta l = 0$, and $\Delta m = 0, \pm 1$ when $\langle a|\vec{p}|b\rangle = 0$ and $\langle a|\vec{m}|b\rangle \neq 0$.

In the following the lower state $|a\rangle$ will be taken as the ground-state $|0\rangle$ which is assumed to belong to the identity representation. Only transitions from the ground state will be considered. With the above assumption only the symmetry properties of the upper state $|b\rangle$ will be of interest. If the transition $|0\rangle \rightarrow |b\rangle$ is either purely electrically allowed or purely magnetically allowed, the state $|b\rangle$ is called a pure state. Transitions to pure upper states are optically inactive. Optical rotation always involves transition to mixtures of hydrogen-like atomic states, one electrically, the other magnetically allowed. When two states predominate in a mixed state with one being electrically and one magnetically accessible from the ground state, they give rise to two mixed states.

The pair of transitions from the ground state occurs at different regions of the spectrum. A large absorption band is usually associated with the electrically allowed transition while only a shoulder appears for a magnetically allowed transition. These two transitions should show rotation of opposite signs. This is responsible for the high resolving power of the CD spectra. This property is illustrated for the one-electron case using the harmonic oscillator model.

Transitions from the ground state (000) to the two possible mixtures of (100) and (011) are next considered. These two upper states are mixed by the perturbation $V = Axyz$ to give the following mixtures

$$\langle 100 \rangle = \langle 100 \rangle + C\langle 011 \rangle \quad (19)$$

$$\langle 011 \rangle = \langle 011 \rangle - C\langle 100 \rangle \quad (20)$$

The mixing coefficient is

$$C = \frac{\langle 011|\bar{V}|100\rangle}{E_{100} - E_{011}} \quad (21)$$

The coefficient C contains an energy factor $1/(E_{100} - E_{011})$ which can be large when the two levels are close. The rotation (100) means that the motion in the x , y , and z directions is characterized by the quantum states 1, 0, and 0, respectively. The energy diagram is shown in Figure 6.

The rotatory strengths are

$$R_E \cong C\langle 000|\vec{p}|100\rangle \cdot \langle 011|\vec{m}|000\rangle \quad (22)$$

$$R_M \cong -C\langle 000|\vec{p}|100\rangle \cdot \langle 011|\vec{m}|000\rangle \quad (23)$$

The above property is not restricted to the one-electron model, nor is it restricted to the harmonic oscillator approximation. It is a general result as pointed out in the following. Both in the one-electron model and the coupled oscillator model at least two functional groups of an optically active molecule are involved. In the one-electron case the electrically allowed transition is localized in one of the functional groups and the magnetically allowed transition in the other, while in the coupled oscillator model both transitions are electrically allowed.

V. THE ONE-ELECTRON MODEL

It is important to note that for every active transition a pair of transitions, one electrically allowed and the other magnetically allowed, is involved. The one-electron model usually involves as the low-energy state a strong magnetically allowed transition with a small amount of an electrically allowed transition mixed in. The electron involved is often a lone-pair electron. Actually a molecule with only one important chromophore should be adequately treated by the one-electron theory. There are two different approaches using the one-electron method.

(1)²⁹ The nonbonding electron on the oxygen of a carbonyl chromophore is excited to an antibonding state on the carbon and oxygen. This transition is strongly magnetically allowed and is weakly electrically allowed. The usual explanation is that an electrical transition localized in a vicinal group lying in the far-uv is mixed in. In this approach the molecule is treated in such a way that it consists of mainly two groups: the chromophore group in which the magnetic transition is localized and the vicinal group in which the electric transition is localized. The static perturbation mixes the two transitions. The molecular

(29) D. J. Caldwell and H. Eyring, *Rev. Mod. Phys.*, **35**, 577 (1963).

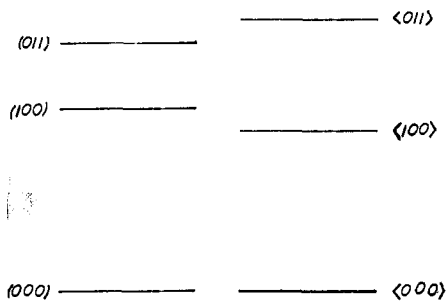

Figure 6.—Energy-level diagram.

wave functions are simply the product of the chromophoric and the vicinal wave functions.

$$\psi_0^1 \phi_0^1 = \psi_0^0 \phi_0^0 + \sum_l \frac{V_{n\pi^*,l}}{(E_{n\pi^*} + E_l)} \psi_{n\pi^*}^0 \phi_l^0 \quad (24)$$

$$\psi_{n\pi^*}^1 \phi_0^1 = \psi_{n\pi^*}^0 \phi_0^0 + \sum_l \frac{V_{n\pi^*,l}}{E_{n\pi^*} - E_l} \psi_0^0 \phi_l^0 \quad (25)$$

$$\psi_0^1 \phi_l^1 = \psi_0^0 \phi_l^0 - \sum_l \frac{V_{n\pi^*,l}}{E_{n\pi^*} - E_l} \psi_{n\pi^*}^0 \phi_0^0 \quad (26)$$

The rotatory strengths are

$$R_{0,n\pi^*} = i \frac{2E_l V_{n\pi^*,l}}{E_l^2 - E_{n\pi^*}^2} \vec{p}_{0l} \cdot \vec{m}_{n\pi^*,0} \quad (27)$$

$$R_{0,l} = -i \frac{2E_l V_{n\pi^*,l}}{E_l^2 - E_{n\pi^*}^2} \vec{p}_{0l} \cdot \vec{m}_{n\pi^*,0} \quad (28)$$

Therefore

$$R_{0,n\pi^*} + R_l \approx 0 \quad (29)$$

(2)³⁰ The second approach is based on the classification of the molecular states according to the symmetry of the chromophore. There are two types of states which are important: those which transform either like polar vectors or axial vectors (the former is electrically allowed and the latter is magnetically allowed). Consider the following molecular states: β transforms like a polar vector, E allowed (*i.e.*, it forms a normal subgroup); α transforms like an axial vector, M allowed (*i.e.*, it forms a normal subgroup); ρ and σ are the rest of the states.

$$|\beta\rangle = |\beta\rangle - \sum_{\alpha} \frac{(\alpha|V|\beta)}{E_{\alpha} - E_{\beta}} |\alpha\rangle - \sum_{\rho} \frac{(\rho|V|\beta)}{E_{\rho} - E_{\beta}} |\rho\rangle \quad (30)$$

$$|\alpha\rangle = |\alpha\rangle + \sum_{\beta} \frac{(\alpha|V|\beta)}{E_{\alpha} - E_{\beta}} |\beta\rangle - \sum_{\rho} \frac{(\rho|V|\alpha)}{E_{\rho} - E_{\alpha}} |\rho\rangle \quad (31)$$

$$|0\rangle = |0\rangle - \sum_{\sigma} \frac{(\sigma|V|0)}{E_{\sigma} - E_0} |\sigma\rangle \quad (32)$$

$$R_{0\beta} = +i(0|\vec{p}|\beta) \cdot \left[\sum_{\alpha} \frac{(\alpha|V|\beta)}{E_{\alpha} - E_{\beta}} (\alpha|\vec{m}|0) + \sum_{\rho} \frac{(\rho|V|0)}{E_{\rho} - E_0} (\beta|\vec{m}|\rho) \right] \quad (33)$$

$$R_{0\alpha} = -i \left[\sum_{\beta} \frac{(\alpha|V|\beta)}{E_{\alpha} - E_{\beta}} (0|\vec{p}|\beta) - \sum_{\rho} \frac{(\rho|V|0)}{E_{\rho} - E_0} (\rho|\vec{p}|\alpha) \right] \cdot (\alpha|\vec{m}|0) \quad (34)$$

$$\sum_{\beta} R_{0\beta} + \sum_{\alpha} R_{0\alpha} = i \left[\sum_{\alpha,\beta} \frac{(\alpha|V|\beta)}{E_{\alpha} - E_{\beta}} - \sum_{\alpha,\beta} \frac{(\alpha|V|\beta)}{E_{\alpha} - E_{\beta}} \right] \cdot (0|\vec{p}|\beta) \cdot (\alpha|\vec{m}|0) + \sum_{\rho} \frac{(\rho|V|0)}{E_{\rho} - E_0} \left[\sum_{\beta} (0|\vec{p}|\beta) \cdot (\beta|\vec{m}|\rho) - \sum_{\alpha} (0|\vec{p}|\alpha) \cdot (\alpha|\vec{m}|0) \right] = 0 \quad (35)$$

Both approaches imply that a nonvanishing rotatory strength is always involved in a pair of transitions, one strongly electrically allowed and one strongly magnetically allowed.

VI. KIRKWOOD'S COUPLED OSCILLATOR MODEL

The main feature of this model is to consider a molecule as made of N groups. It is assumed that there is no electron exchange between any pair of groups. The molecular wave functions are simply the product of the group wave functions. Whenever there is more than one group with the same electronic structure, a linear combination of the appropriate group wave functions should be used. Only two extreme cases have so far been considered:^{2,3,31} (1) nondegenerate case, molecules with no two groups having the same electronic structure; (2) degenerate case, all the groups are alike. The intermediate cases have not so far been treated but could be; however, the separate consideration of the nondegenerate and degenerate cases, which will be presented here, enables one to analyze and understand the general problem without going through the details.

It should be emphasized that the molecular wave functions completely determine the rotatory and absorption properties. The oscillator strength as well as the rotatory strength can then be calculated.

It is appropriate to consider the mechanism of rotation for a model and the important question of how to divide a molecule into groups. In this model two electronic oscillators, dissymmetrically oriented as in Figure 7, will lead to rotation of the plane of polarization. It is important that d and the coupling constant k_{12} both be different from zero. In the actual molecule any transition localized in a functional group can be taken as an oscillator. This functional group is the chromophore. The model requires at least two chromophoric groups dissymmetrically oriented in space and

(30) J. A. Schellman, *J. Chem. Phys.*, **44**, 55 (1966).

(31) J. G. Kirkwood, *ibid.*, **5**, 479 (1937).

coupled electronically. One feature of this model is that when two chromophores are coplanar no rotation results. This is a result of the asymmetry requirement. When two chromophores are widely separated in space and consequently are noninteracting electronically, the coupling constant is zero and there is no rotation.

From the above discussion it is clear that the molecule is to be divided up according to the chromophoric groups it contains. The nondegenerate and degenerate cases differ in that for the former no two chromophores are the same while in the later no two chromophores are different. A polymer with only one kind of repeating unit necessarily belongs to the degenerate case. Polymers with different residues are treated as nondegenerate.

When a molecule contains no chromophores with absorption in the visible or near-ultraviolet region, the division of a molecule into groups is unavoidably ambiguous. This is the case for molecules with asymmetric carbons for which the model was originally proposed.

The most important feature of the rotatory spectra of polymers is the so-called exciton splitting. It is observed experimentally that the polymers' CD spectra often show two rotatory bands of opposite sign centered at an absorption maximum³² (Figure 8). This was subsequently explained in terms of the exciton model of the molecular crystals. In essence this is nothing but the result of coupling of chromophores. This can be best understood by considering the dimer in which there are two similar chromophores coupled electronically. The molecular ground-state function is

$$\psi_0 = \phi_{01}\phi_{02} \quad (36)$$

The molecular σ -excited state is doubly degenerate. Its wave function is

$$\psi_{\sigma,\pm} = \frac{1}{\sqrt{2}}(\phi_{\sigma 1}\phi_{02} \pm \phi_{01}\phi_{\sigma 2}) \quad (37)$$

The symmetric and antisymmetric states denoted by + and - are separated spectroscopically. Their rotatory strengths are

$$R_{\pm} = \pm \frac{\alpha \epsilon_{\sigma}}{4} \vec{r}_{12} \cdot (\vec{q}_{\sigma 1} \times \vec{q}_{\sigma 2}) \quad (38)$$

Here ϵ_{σ} is the common energy of the two states without the perturbation (Figure 9 is the energy-level diagram), $\alpha \simeq 1/137$ is the hyperfine structure constant, \vec{r}_{12} is the vector distance between chromophores, and $\vec{q}_{\sigma 1}$ and $\vec{q}_{\sigma 2}$ are the transition dipole moments. The electric transition of one monomer appears to be a magnetic transition to the second monomer, and *vice*

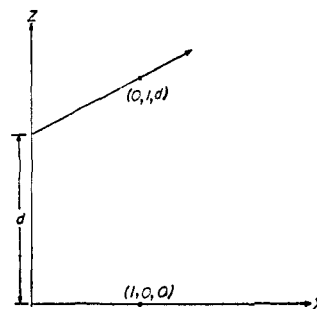

Figure 7.—Coupled oscillator model.

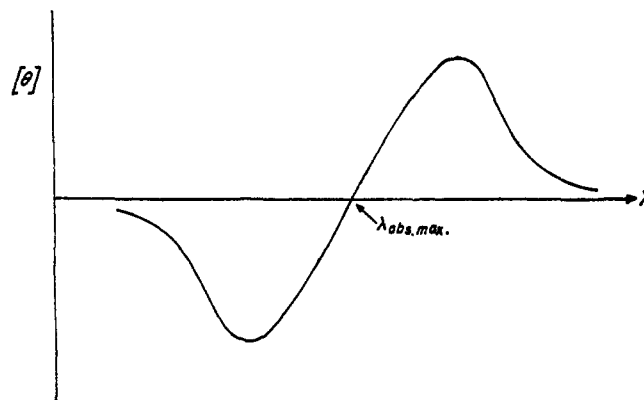

Figure 8.—Exciton splitting.

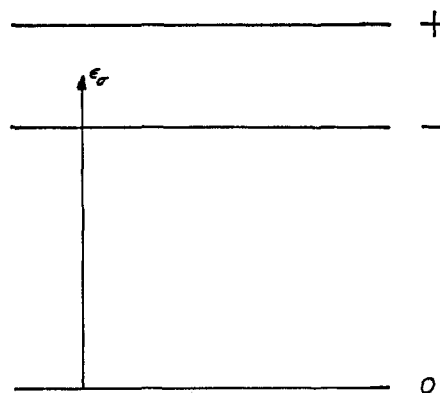

Figure 9.—Energy-level diagram.

versa. The rotatory strengths are both derived from the same coupled oscillator factor $\vec{r}_{12} \cdot (\vec{q}_{\sigma 1} \times \vec{q}_{\sigma 2})$. The exciton splitting gives

$$R_{+} + R_{-} = 0 \quad (39)$$

However, the exciton splitting is not peculiar to the degenerate case alone. Two different chromophores coupled electronically are also expected to have their energy levels repel each other. Thus the zeroth order wave functions for the common ground state and the two different excited states are

$$\chi_0^0 = \psi_0 \phi_0 \quad (40)$$

$$\chi_{\sigma}^0 = \psi_{\sigma} \phi_0 \quad (41)$$

$$\chi_{\tau}^0 = \psi_0 \phi_{\tau} \quad (42)$$

(32) I. Tinoco, Jr., *J. Am. Chem. Soc.*, **86**, 297 (1964).

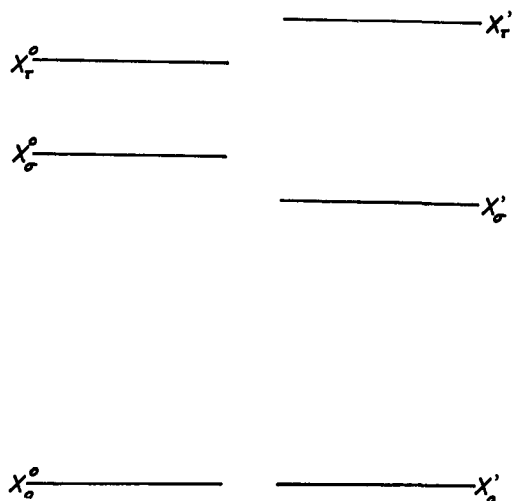

Figure 10.—Energy-level diagram.

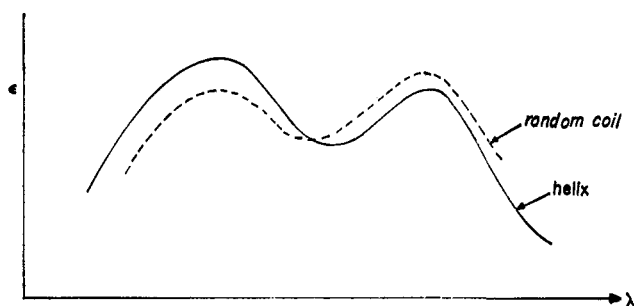

Figure 11.—Hypochromism.

The first-order wave functions are obtained by mixing the zeroth-order wave functions. The ground state is mixed with a molecular state in which both groups are excited.

$$\chi_0' = \psi_0\phi_0 - \frac{V}{\epsilon_\sigma + \epsilon_\tau} \psi_0\phi_r \quad (43)$$

The excited states χ_σ^0 and χ_τ^0 are mixed with each other.

$$\chi_\sigma' = \psi_\sigma\phi_0 + \frac{V}{\epsilon_\sigma - \epsilon_\tau} \psi_0\phi_r \quad (44)$$

$$\chi_\tau' = \psi_0\phi_\tau - \frac{V}{\epsilon_\sigma - \epsilon_\tau} \psi_\sigma\phi_0 \quad (45)$$

It should be noted that the two different excited states are the two zeroth-order wave functions mixed with coefficients of opposite sign. Figure 10 is the energy diagram.

The two rotatory strengths are

$$R_\sigma = +\alpha \frac{\epsilon_\sigma\epsilon_\tau}{\epsilon_\sigma^2 - \epsilon_\tau^2} V \vec{r}_{12} \cdot (\vec{q}_{\sigma 1} \times \vec{r}_{r2}) \quad (46)$$

$$R_\tau = -\alpha \frac{\epsilon_\sigma\epsilon_\tau}{\epsilon_\sigma^2 - \epsilon_\tau^2} V \vec{r}_{12} \cdot (\vec{q}_{\sigma 1} \times \vec{q}_{r2}) \quad (47)$$

from which it follows that

$$R_\sigma + R_\tau = 0 \quad (48)$$

This conclusion is the same as in the degenerate case. Accordingly exciton splitting in general is the result of the fact that two chromophores are coupled electronically.

The most important feature of the absorption spectra of polymers is the borrowing of intensities of absorption bands.³³ This is illustrated in the Figure 11. According to the exciton model when the polymer goes through a helix-random-coil transition, one of the two coupled absorption bands 1 and 2 will increase and the other will decrease in intensity. This property has so far no experimental verification. The points to be made here are: (1) this property is also expected for the non-degenerate case; (2) this property is closely related to the exciton splitting. The connection is in the mixing of states with coefficients having opposite signs. Using eq 43-45, it is easy to show that

$$f_{\sigma 1} = \frac{2m}{3\hbar^2} \epsilon_{\sigma 1} \vec{q}_{\sigma 1}^2 + \frac{8m}{3\hbar^2} \frac{\epsilon_\sigma\epsilon_\tau}{\epsilon_\sigma^2 - \epsilon_\tau^2} V_{12}^{\sigma\tau} \vec{q}_{\sigma 1} \cdot \vec{q}_{r1} \quad (49)$$

$$f_{r2} = \frac{2m}{3\hbar^2} \epsilon_{r2} \vec{q}_{r2}^2 - \frac{8m}{3\hbar^2} \frac{\epsilon_\sigma\epsilon_\tau}{\epsilon_\sigma^2 - \epsilon_\tau^2} V_{12}^{\sigma\tau} \vec{q}_{\sigma 1} \cdot \vec{q}_{r2} \quad (50)$$

This property, if it is sensitive enough to be detectable, can be used to establish the coupling of a wide CD exciton splitting. Two CD bands are coupled when their corresponding absorption bands show the effect of borrowing of intensities.

VII. HELICAL SENSE, HELICAL CONTENT, AND MOFFITT'S CONSTANT

Moffitt's constant, b_0 , is similar to the rotatory strength in many ways. The way its sign and order of magnitude correlate with structural features, the way its numerical value is obtained from the off-absorption rotatory data and from circular dichroism, and its symmetry properties parallel those of the rotatory strength.

The molecular rotation in regions well removed from absorption is given by Rosenfeld's equation which is similar in form to Drude's earlier equation. Equations 51 and 52 are the same as eq 13 except that they are written in terms of the frequency instead of the wavelength.

$$[\phi] = \sum_i \frac{a_i \nu^2}{\nu_i^2 - \nu^2} \quad (51)$$

where

$$a_i = \frac{96\pi N}{hc} \frac{n_\nu^2 + 2}{3} R_i \quad (52)$$

N is Avogadro's number; n_r is the index of refraction for light of frequency ν . R_i is the rotatory strength and is defined in eq 14. The sign of the rotatory strength determines the sign of the corresponding Cotton effect. Its order of magnitude covers a wide range and provides insight into the nature of the transition.¹¹

The numerical value of the rotatory strength can be obtained from the off-absorption rotatory data. However, Moffitt and Moscovitz^{6,19} were able to show that it can also be obtained from circular dichroism. Circular dichroism arises from the difference of absorption coefficients for the left- and the right-handed circularly polarized light.

$$\theta = \frac{1}{4}(k_l - k_r) \quad (53)$$

The rotatory strength, R_i , is related to θ by

$$R_i = \frac{3\hbar c}{4\pi^2 N_1} \int \frac{\theta_i(\lambda) d\lambda}{\lambda} \quad (54)$$

where N_1 is the number of molecules per cubic centimeter.

Once the circular dichroism curve for a certain transition of an optically active compound is determined experimentally, the rotatory strength can be obtained by performing the integration occurring in eq 54. The rotatory strength is a pseudo-scalar which changes sign for a mirror-image system. This feature is widely used to correlate the stereoconformation to the sign of the Cotton effect.

The rotatory properties of the helical molecules were first studied by Moffitt.³⁴ In his study helical molecules were shown to exhibit anomalous dispersion which does not follow Drude's equation. Instead the molecular rotation is given by

$$[\phi] = \sum_i \frac{a_i \lambda_i^2}{\lambda^2 - \lambda_i^2} + \sum_i \frac{b_i \lambda_i^4}{(\lambda^2 - \lambda_i^2)^2} \quad (55)$$

where b_i is different from zero; the second term is the anomalous dispersion.

It was further shown that three constants, a_0 , b_0 , and λ_0 , are sufficient to characterize the experimental data.

$$[\phi] = \frac{a_0 \lambda_0^2}{\lambda^2 - \lambda_0^2} + \frac{b_0 \lambda_0^4}{(\lambda^2 - \lambda_0^2)^2} \quad (56)$$

The relation between a_0 , b_0 , λ_0 and a_i , b_i , λ_i are given by the following set of equations.

$$a_0 \lambda_0^2 = \sum_i a_i \lambda_i^2 \quad (57)$$

$$b_0 \lambda_0^4 = \sum_i b_i \lambda_i^4 \quad (58)$$

$$b_0 \lambda_0^6 = \sum_i b_i \lambda_i^6 \quad (59)$$

The set of constants, a_0 , b_0 , and λ_0 , takes account of the fact that several transitions jointly contribute.

From eq 57-59, we see that transitions in the long wavelength end of the spectrum are weighted heavier than those in the short wavelength end. Rearranging eq 56 we obtain

$$[\phi](\lambda^2 - \lambda_0^2) = a_0 \lambda_0^2 + b_0 \lambda_0^4 \left(\frac{1}{\lambda^2 - \lambda_0^2} \right) \quad (60)$$

A plot of $[\phi](\lambda^2 - \lambda_0^2)$ against $1/(\lambda^2 - \lambda_0^2)$ obtained by adjusting the value of λ_0 such that the plot is linear is called a Moffitt-Yang plot. The intercept and the slope give respectively a_0 and b_0 . An example is provided by poly(γ -benzyl glutamate) dissolved in ethylene dichloride: $\lambda_0 = 212 \mu\text{m}$, $a_0 = 205^\circ$, and $b_0 = -635^\circ$. It is noted that the Moffitt-Yang plot makes use of the off-absorption rotatory data.

The parameter b_0 is common known as Moffitt's constant. Its sign was thought to determine the helical sense of twist. A negative sign of b_0 is interpreted to indicate that the helix under study is right handed while a positive sign indicates that the helix is left handed. The magnitude of b_0 has been used as a measure of the helical content: 100% helix for a value of b_0 around -635° and a random coil for a zero value of b_0 .

Moffitt was able to justify the anomalous dispersion of helical molecules by considering the helix as a molecular crystal.^{2,3} It was shown that the molecular rotation is determined by

$$[\phi] = \sum_i \frac{c_i \nu^2}{\nu_i^2 - \nu^2} + \frac{d_i \nu_i^2 \nu^2}{(\nu_i^2 - \nu^2)^2} \quad (61)$$

After changing the variable from frequency to wavelength ($\nu_i = c/\lambda_i$, $\nu = c/\lambda$) eq 6 can be cast into the form ready for comparison with eq 55.

$$[\phi] = \sum_i \frac{(c_i + d_i) \lambda_i^2}{\lambda^2 - \lambda_i^2} + \frac{d_i \lambda_i^4}{(\lambda^2 + \lambda_i^2)^2} \quad (62)$$

It follows from a comparison of eq 55 and 61 that

$$a_i = c_i + d_i \quad (63)$$

$$b_i = d_i$$

Before examining the quantum mechanical nature of a_0 and b_0 (or equivalently a_i and b_i or c_i and d_i) it will be shown below that b_i and hence b_0 can be obtained from circular dichroism like the rotatory strength. This will be done by casting one of the Kramers-Kronig relations into the form of eq 56.

The Kramers-Kronig relations³⁵ are

$$\phi(\omega) = \frac{2\omega^2}{\pi} \int_0^\infty \frac{\theta(\Omega)}{\Omega(\Omega^2 - \omega^2)} d\Omega \quad (64)$$

(34) W. Moffitt and J. T. Yang, *Proc. Natl. Acad. Sci. U. S.*, **42**, 596 (1956).

(35) C. A. Emeis, L. J. Oosterhoff, and G. de Vries, *Proc. Roy. Soc. (London)*, **A297**, 54 (1967).

$$\theta(\omega) = -\frac{2\omega}{\pi} \int_0^\infty \frac{\phi(\Omega)}{\Omega^2 - \omega^2} d\Omega \quad (65)$$

where

$$\phi(\omega) = \frac{\omega}{2c}(n_1 - n_r) \quad (66)$$

is the rotation of the plane of polarization in radians per unit length and

$$\theta(\omega) = 1/4(k_1 - k_r) \quad (67)$$

is the ellipticity. The dash above the integral sign in eq 64 and 65 means that only the principal value of the integral is to be taken. The complete CD spectrum, $\theta(\omega)$, determines the complete ORD spectrum, $\phi(\omega)$, and *vice versa*.

Introducing the assumption of partial quantities so that the rotation and the ellipticity of each absorption region can be separated, *i.e.*

$$\phi(\omega) = \sum_i \phi_i(\omega) \quad (68)$$

$$\theta(\omega) = \sum_i \theta_i(\omega) \quad (69)$$

we obtain

$$\phi_i(\omega) = \frac{2\omega^2}{\pi} \int_{D_i} \frac{\theta_i(\Omega)}{\Omega(\Omega^2 - \omega^2)} d\Omega \quad (70)$$

where $\phi_i(\omega)$ and $\theta_i(\omega)$ are the *i*th rotation and the *i*th ellipticity; D_i means only the *i*th ellipticity θ_i is taken into account. Equation 70 is a Kramers-Kronig relation between a partial rotation and its corresponding partial ellipticity. Introducing the *i*th absorption maximum ω_i , we find

$$\begin{aligned} \phi_i(\omega) &= \frac{2\omega^2}{\pi} \int \frac{\theta_i(\Omega)}{\Omega(\Omega^2 - \omega_i^2 + \omega_i^2 - \omega^2)} d\Omega = \\ & \frac{2\omega^2}{\pi} \int \frac{\theta_i(\Omega)}{\Omega(\omega_i^2 - \omega^2) \left(1 - \frac{\omega_i^2 - \Omega^2}{\omega_i^2 - \omega^2}\right)} d\Omega \end{aligned} \quad (71)$$

In regions well-removed from the *i*th absorption region, $|\omega_i^2 - \Omega^2| \ll |\omega_i^2 - \omega^2|$ because for Ω very different from ω_i , $\theta(\Omega)$ is small and negligible. Equation 71 can therefore be approximated by

$$\begin{aligned} \phi_i(\omega) &= \frac{2\omega^2}{\pi(\omega_i^2 - \omega^2)} \int \frac{\theta_i(\Omega)}{\Omega} d\Omega + \\ & \frac{2\omega^2}{\pi(\omega_i^2 - \omega^2)^2} \int \frac{\theta_i(\Omega)(\omega_i^2 - \Omega^2)}{\Omega} d\Omega \end{aligned} \quad (72)$$

Equation 72 has the same frequency dependence as eq 61. By comparing the first term of the two equations it follows that

$$R_i = \frac{3\hbar c}{4\pi^2 N_1} \int \frac{\theta_i(\nu)}{\nu} d\nu \quad (73)$$

where N_1 is the number of molecules per cubic centimeter. This simply reproduces the equation used by Moffitt and Moscovitz in obtaining the rotatory strength from circular dichroism. By comparing the second term of the two equations and using eq 63, it follows that

$$a_i = \frac{F_\nu}{\alpha} \frac{3\hbar c}{4\pi^2 N_1} \int \frac{\theta_i(\nu') \left(\frac{\nu'^2}{\nu^2} - 2\right) d\nu'}{\nu'} \quad (74)$$

$$b_i = -\frac{F_\nu}{\alpha} \frac{3\hbar c}{4\pi^2 N_1} \int \frac{\theta_i(\nu') \left(\frac{\nu'^2}{\nu^2} - 1\right) d\nu'}{\nu'} \quad (75)$$

where

$$F_\nu = \frac{48Ne^2}{\hbar^2 c^2}$$

N is Avogadro's number, and $\alpha = e^2/\hbar c \cong 1/137$ is the hyperfine structure constant.

The value of b_i , calculated from circular dichroism by means of eq 75 should be used to obtain Moffitt's constant, b_0 , from eq 58 and 59. This should be compared with the value obtained from the slope of the Moffitt-Yang plot and also with the value calculated theoretically using the equation to be developed later.

It is interesting to note that not only can the Moffitt-Moscovitz equation (73) be obtained from the Kramers-Kronig relations but also Moffitt's constant b_0 . We also note that the following equation

$$f_i = \frac{m_e c}{\pi N e^2} \int k_i(\nu') d\nu' \quad (76)$$

suggested by Mulliken²⁶ for calculating the oscillator strength from the experimental absorption curve can be obtained from another pair of Kramers-Kronig relations relating the ordinary dispersion to the absorption²⁵

$$n(\omega) - 1 = \frac{2}{\pi} \int_0^\infty \frac{k(\Omega)}{\Omega^2 - \omega^2} d\Omega \quad (77)$$

In the exciton model for the helix, Moffitt assumed that a helix is composed of N identical interacting residues. There are three mechanisms which lead to rotation. The first is the one-electron effect which is due to the electrostatic perturbation of the side-chain groups on the chromophores. This effect is usually considered to be small. The second and the third are the coupled oscillator effect. Moffitt's theory is just the degenerate coupled oscillator theory of Kirkwood. Rotation is due to the intraband interaction in which two different residues are simultaneously excited to the same excited state and the electrical transition of one of the residues appears as a magnetic transition to the other and *vice versa*. Rotation is also due to the interband

interaction in which two different residues are simultaneously excited to two different excited states.

The success of the exciton model lies in its correct prediction of the on-absorption property, specifically, the exciton splitting. According to the exciton model, the excited states of the helix form energy bands. The rotatory strength for the K sublevel of the σ -exciton band is due to the intraband interaction

$$R_{\sigma k} = \frac{\alpha}{4} \epsilon_{\sigma} \sum_i \sum_j C_{ik}^{\sigma*} C_{jk}^{\sigma} \vec{r}_{ij} \cdot (\vec{q}_{\sigma i} \times \vec{q}_{\sigma j}) \quad (78)$$

On summing over all the substates of the exciton band, the rotatory strength of the total band is zero.

$$R_{\sigma} = \sum_k R_{\sigma k} = 0 \quad (79)$$

Moffitt's constant for the σ -exciton band in the exciton model is

$$b_{\sigma} = -\frac{2F_{\nu}}{\alpha N} \sum_k R_{\sigma k} (E_{\sigma k} - \epsilon_{\sigma}) / \epsilon_{\sigma} = -\frac{24N_0 e^2}{\hbar^2 c^2 N} \sum_i \sum_j V_{ij}^{\sigma\sigma} \vec{r}_{ij} \cdot (\vec{q}_{\sigma i} \times \vec{q}_{\sigma j}) \quad (80)$$

Two remarks are in order here. First, Moffitt's constant transforms like a pseudo-scalar changing sign for the mirror-image system. Second, this constant is also derived from the intraband interaction like the exciton splitting

In summary the exciton model correctly predicts the exciton splitting for the on-absorption rotation. This is equivalent to a nonzero Moffitt's constant b_0 which can be obtained from: (1) the slope of the Moffitt-Yang plot, (2) eq 80 calculated theoretically, and (3) experimental circular dichroism using eq 75, 58, and 59.

VIII. THE INTERACTIONS RESPONSIBLE FOR OPTICAL ROTATION

A. In the absence of a precise wave function for a given molecule, calculations have taken two directions. In the static-field method one tacitly makes use of the valence-bond approximation by confining a given transition to a small group of atoms and computing the effect of the average field of the other atoms.

In the dynamic approach use is made of the change in polarization forces which takes place when one or both of the groups are undergoing oscillations. For example, the lowest order approximation to the interaction between two hydrogen atoms at large distances is found by evaluating the integral $\int \psi_{A1s}(1) \psi_{B1s}(2) H \psi_{A1s}(1) \psi_{B1s}(2) d\tau_1 d\tau_2$. This expression has an exponential dependence and decreases rapidly with distance. In this instance the second-order effects outweigh the first-order ones at large distances. Here the major

effect arises from the polarization of one atom in the field of the other. The lowest order effect possible is the dipole-dipole interaction, which averages to zero. The first nonvanishing terms have the familiar $1/R^6$ dependence which would correspond to quadrupole-octupole interactions among others.

The situation is changed when one or both of the groups are undergoing forced oscillations. The dipole-dipole forces no longer average to zero, and the interaction between the two groups has a $1/R^3$ dependence. This is termed the coupled oscillator effect and increases with increasing phase difference between the two groups.

To attain a feeling for the regions where coulombic and polarization forces are dominant, the forces between the two hydrogen atoms may be examined. At a distance of 1 Å the dominant term, the exchange integral, cannot be computed by standard perturbation methods in which the zeroth-order wave function is the product of the individual hydrogen atomic functions.

Such a perturbation attempt leads to the coulombic term of the binding energy, which is 10–15% of the total. At a distance of 3 Å the exchange term has become comparable to the coulombic integral. The dispersion forces ($-6/R^6$ in atomic units for two hydrogen molecules) are comparable if not greater. This may properly be termed a transition region where both coulombic and dispersion forces must be considered. At a distance of 4 Å the coulombic forces have decreased to $1/10$ th the dispersion forces. At further distances the coulombic terms may safely be ignored in computing the total interaction energy between the two atoms.

In the analysis of electromagnetic phenomena, one is not directly interested in the total energy of the system, an important point to remember. The effects in question are still governed by the same types of intramolecular forces—exchange, coulombic, and dispersion—but their relative magnitudes will not necessarily be the same as those of the total energy. We may nevertheless be initially guided by the above considerations when investigating appropriate mechanisms for optical rotatory dispersion.

B. It is not surprising that these two mechanisms do not always give the same sign of rotation. This often places us in the unhappy predicament of requiring mildly precise calculations just to obtain a reliable method for sign predictions.

The quandary takes on two separate aspects according to the type of transition being studied. With the electric dipole transition the dispersion forces are of the dipole-dipole type. The optical rotatory parameter introduced an r into the numerator and the over-all intergroup distance dependence is $1/r^2$. In the case of magnetic dipole oscillations, the electric dipole moment is unchanged while the quadrupole moment changes. The lowest order intergroup forces are the quadrupole-dipole with a $1/R^4$ dependence.

For either transition the coulombic terms must be considered. In optical rotation language the electric dipole transition becomes active through interaction with other electric dipole transitions (dispersion forces in the presence of an electromagnetic field) as well as through the influence of the average (coulombic) dissymmetric field around the group. The situation with magnetic dipole transitions is similar except that the dispersion forces are of a lower order.

It we first confine ourselves to transitions which interact with a dissymmetric array of neutral atoms (the crudest approximation to a molecular system), the average field from neighboring groups will have an exponential dependence. For example, the average potential due to a hydrogen atom is $-e^{-2R}(1 + 1/R)$ in atomic units. The effect of the dispersion forces in the presence of the radiation field introduces a $1/R^2$ term for electric dipole transitions and a $1/R^4$ term for magnetic dipole transitions. It is certainly true that at large distances the dispersion terms will predominate owing to their less severe distance dependence. In most cases of interest the interacting groups will have no unpaired electrons. This allows the division of the interaction region into three parts. In the first region the exchange forces have become negligible, and the coulombic terms predominate over the dispersion forces. This region is probably quite narrow and the groups must be nearly touching, just beyond the point where the exchange integrals are appreciable. In the intermediate region the two effects are comparable and not always of the same sign. Finally, as mentioned, there will be a region at large distances where the dispersion forces are the sole effect.

C. It happens that the coulombic contribution to the optical rotatory parameter depends on both the exponential wave functions of the chromophore and the neighboring groups. The assessment of effective atomic numbers for molecular wave functions is no easy task. One must first recognize that only with the hydrogen atom is there a well-defined effective atomic number constant at all distances. For example, in the H_2^+ ion the exact electronic solution leads to a complicated function of the elliptical coordinate which reduces to e^{-r} near either nuclei and e^{-2r} at large distances from both nuclei, where the electron sees essentially the combined $+2$ charge of the two protons. A variation calculation on the sum of the hydrogen-like functions gives a value of about 1.2 for the exponent. In the region of maximum charge density, important for the bulk of the binding energy, this value represents a fairly good coverage for the actual exponential-like function. This will, however, tend to overestimate the charge density in outlying regions, where the exponent must approach 2.

This illustrates the well-known fact that a wave function which is adequate for calculating the total energy

of a system may be totally inadequate in the regions of rarified electron atmosphere. The situation is similar in many electron systems. The helium atom must satisfy the equation

$$\left[-\frac{1}{2}(\nabla_1^2 + \nabla_2^2) - \frac{2}{r_1} - \frac{2}{r_2} + \frac{1}{r_{12}} \right] \psi(r_1, r_2) = E\psi(r_1, r_2)$$

in all regions of space. The zeroth-order estimate to this problem provides a lower bound to the charge density at large distances. Ignoring the repulsion term gives

$$\psi_0(r_1, r_2) = e^{-2r_1} e^{-2r_2}$$

$$E_0 = -2 \times \frac{1}{2}(4) \text{ au}$$

The first improvement to the wave function computes the average field of one electron

$$\frac{1}{r} [1 - e^{-4r}(1 + 2r)]$$

and adds it to the field of the doubly charged nucleus $-2/r$. This provides an improved approximation to the field in which either electron moves in the presence of the other. Reiteration of this process leads to a series of complicated wave functions obtained by numerical integration. The best exponential approximations to these self-consistent field functions approach the value $e^{-1.7r}$. This may be taken as the point of departure in determining the functional behavior at large distances; the appropriate equation for one of the electron is

$$\left[-\frac{1}{2}\nabla^2 - \frac{1}{r} - e^{-2(1.7)r} \left(\frac{1}{r} + 1.7 \right) \right] \phi = E\phi$$

As $r \rightarrow 0$ the potential approaches $-2/r$, and as $r \rightarrow \infty$ it becomes $-1/r$.

It therefore seems reasonable that the best exponential estimate of this equation would be a function of the form $e^{-Z(r)r}$, where r varies continuously from 2 near the nucleus to 1 at large distances with an average value for energy purposes of 1.7. Such a solution would have a quite complex dependence on r in order to satisfy an eigenvalue problem with a constant E . If this requirement is relaxed, a solution which numerically satisfies the equation in the spherical shell $r_0 \pm dr$ is $e^{-Z(r_0)r}$, where $Z(r_0) = 1 + e^{-2(1.7)r_0}(1 + 1.7r_0)$. This is the self-consistent field potential written in the form $-Z(r)/r$ where $Z(r)$ is evaluated at r_0 . The energy in this spherical shell is given by

$$E(r_0) = -\frac{1}{2}Z^2(r_0)$$

If $\rho(r_0)$ is the electron density in the spherical shell, the total energy will be given by

$$E = \int_0^\infty E(r_0)\rho(r_0) dr_0$$

We are not especially interested in the energy; however, this will be a good check on the consistency of our results.

The next problem is to find $\rho(r_0)$. Normalization of the $e^{-Z(r_0)r}$ functions is out of the question, since they only numerically satisfy an eigenvalue equation in a limited region of space. One may divide the region into spherical shells as before with average radii of \bar{r}_n , $n = 1, 2, \dots$. The electron may be considered to satisfy the equations

$$\left[-\frac{1}{2}\nabla^2 - \frac{Z(r_n)}{r} \right] \phi_n(r) = E(r_n)\phi_n(r)$$

$$n = 1, 2, \dots$$

The fractional charge in each region is now obtained by the boundary conditions

$$\phi_n(r_{n,n+1}) = \phi_{n+1}(r_{n,n+1})$$

$$\frac{d\phi_n}{dr}(r_{n,n+1}) = \frac{d\phi_{n+1}}{dr}(r_{n,n+1})$$

where $r_{n,n+1}$ is the radius of the boundary between regions n and $n + 1$. In order to satisfy both boundary conditions, it will be necessary to introduce the solutions to the hydrogen problem which do not vanish at infinity for all regions except the outer one.

This having been done for all the electrons of a many electron system, one is led to the expectation that at large distances the appropriate antisymmetrized function will have the standard form

$$A|(1s)(\bar{1s})(2s)(\bar{2s})(2P_x)(\bar{2P}_x)\dots|$$

where A is a constant obtained from the "normalization" procedure above, and the determinantal function is identical in form with the one used in energy calculations except that all Z_{eff} are equal to unity. It is worth noting that if the over-all atomic wave function is normalized in the standard way, the use of the actual atomic number or even the Slater average values of Z_{eff} will underestimate the charge density, whereas the value of i will greatly overestimate it.

If the interacting groups are sufficiently close that in the region of maximum overlap one or both of the effective atomic numbers has not reached its limiting value of 1, the above procedure must be modified. A working criterion might perhaps be to require the region of overlap to include no more than 1-2% of the total electron cloud of each group. For example, in hydrogen about 6% of the charge lies outside a sphere of radius 3 ($\sim 1.5 \text{ \AA}$) and only 0.05% outside a radius of 6.

D. The next approximation is to divide the molecule into molecular groups. For example, the dissymmetric interactions in 3-methylcyclopentanone may be approximated by suitably oriented ethane and acetone molecules. This leads to the investigation of the fields

of simple molecules, a problem considerably more complex than for isolated atoms. Some of the salient features may be examined by considering two simple examples H_2 and Li^{2+} .

Every neutral molecule, no matter how symmetrical, has a nonvanishing multipole moment of some order. Most nonpolar molecules have permanent quadrupole moments, which lead to potential energies varying as $1/R^3$. This means that at large enough distances the exponential coulombic terms will be outweighed by the multipole terms. It will happen that, although the charge density of the H_2 molecule at large distances may be less than the combined density of two hydrogen atoms, the field will be greater because of the anisotropy. This does not mean that the coulombic terms may be ignored at all distances. The distances where they are comparable are the same order of magnitude as the intramolecular distances of importance in optical rotation phenomena.

At small distances the multipole expansion breaks down and the force field must be obtained by integration over the charge density of the entire molecule.

If the valence-bond approximation for the hydrogen molecule is used, the field is

$$\frac{1}{2(1+S^2)} \iint [\psi_A(1)\psi_B(2) + \psi_A(2)\psi_B(1)]^2 \times$$

$$\left[-\frac{1}{r_{AP}} - \frac{1}{r_{BP}} + \frac{1}{r_{1P}} + \frac{1}{r_{2P}} \right] d\tau_1 d\tau_2$$

where r_{AP} , r_{BP} , r_{1P} , r_{2P} are the distances of the charges to the field point P . This may be rewritten

$$\frac{1}{1+S^2} [V_H(A) + V_H(B)] -$$

$$\frac{S^2}{r_A} - \frac{S^2}{r_B} + 2S \int \frac{\psi_A(1)\psi_B(1)}{r_{1P}} d\tau_1$$

where $V_H(A)$ is the coulombic field of a hydrogen atom. The last term is a three-center integral, which may be approximated by expanding $1/r_{1P}$ about the midpoint of the bond. This choice of origin for the expansion makes the least possible error in retaining only the first term. The second part of the expression reduces to

$$-\frac{S^2}{r_a} - \frac{S^2}{r_b} + \frac{2S^2}{r_m}$$

which constitutes a quadrupole of moment $1/2 R_{\text{H}_2}^2 S^2$. The first terms would constitute the static field of the unperturbed hydrogen atoms reduced by a factor of $1/(1+S^2)$ were it not for the fact that the effective atomic number in this two-center problem enters in a different way from the isolated atoms. A hydrogen molecule will have an incomplete screening effect at large distances intermediate between the isolated atoms and a helium atom. All three will reduce to an e^{-7}

dependence at large distances, but the normalization constant will vary, being lowest for the helium atom.

The calculation of many electron wave functions from first principles is a full-time job. For the time being one must rely upon the best variation functions available and use them as average values in the above-described renormalization method. These energy-oriented functions are often adequate for obtaining dipole and quadrupole moments. Ideally one would wish to use the experimental values; however, only the total dipole moment of a molecule is measurable. The individual bond moments must often be estimated with the aid of energy-oriented variation functions. Since dipole and quadrupole moments are properties dependent on the relative distribution of the total charge, unlike the coulombic incomplete screening terms, there is more hope that the variation functions may provide reasonable estimates to these quantities.

In LiH there is a nonvanishing dipole moment arising from the combined effects of radius and electronegativity differences. It does not follow that the negative end of the dipole is always toward the most electronegative atom. Once the best possible variation function has been obtained consistent with observed dipole moments, it may be used to estimate the modifications to the coulombic incomplete screening terms upon forming the molecule from the atoms. For this purpose it may be assumed that the inner-shell electrons make a negligible contribution to the electron density at large distances. In a molecule like LiH the first estimate may be obtained from the valence-bond function

$$\psi_{\text{H}}(1)\psi_{\text{Li}}(2) + \psi_{\text{H}}(2)\psi_{\text{Li}}(1) + \lambda\psi_{\text{H}}(1)\psi_{\text{H}}(2)$$

which has been adjusted to give the observed dipole moment without doing violence to the total energy.

A comparison of the Slater effective atomic numbers of individual atoms with those obtained in variation calculations shows that the two are often comparable, and individual atomic screening is a reasonable starting point in assessing the roles of the various mechanisms in optical rotation. In order for this to hold true, the molecular fragments must possess no net charge. It will also very likely occur that the incomplete screening terms from very polar bonds such as C-F will require significant modifications from isolated atomic values.

In summary two interacting groups may contribute to the rotatory parameter through the following mechanisms.

(1) The perturbation of a transition by the average field of the other groups. This field breaks down into the categories: (a) coulombic or incomplete screening with an Ae^{-R} dependence; (b) dipole with a $1/R^5$ dependence;³⁶ (c) quadrupole with a $1/R^6$ dependence.³⁶

(2) The enhancement of the dispersion forces through oscillations leads to (a) a $1/R^2$ dependence for electric dipole transitions; (b) $1/R^4$ dependence for magnetic dipole transitions.

(3) Charge-transfer effects, which occur when the exchange integrals between the groups become appreciable.

(4) Conjugation effects, which require the consolidation of the two groups into a single extended chromophore.

E. It must be emphasized that the problem is only half-solved when the force field in which a chromophore is situated becomes known. There remains the often delicate quantum mechanical question of the electronic paths of least resistance. When a group interacts with a radiation field, oscillation occurs which may be described as lying along the path of least resistance. If this path has a center or plane of symmetry, the induced radiation has equal indices of refraction for right- and left-handed circularly polarized light. When the path lacks these elements of symmetry, the plane of polarization may be rotated. The actual path of least resistance is envisioned in classical parlance as a right- or left-handed helical conductor. (It can be shown that a randomly oriented array of left-handed helices is levorotatory.) The number of turns per unit length is small for electric dipole transitions and large for magnetic dipole transitions. A good estimate of the shape of the path is necessary in order to make even rudimentary calculations. This is where the excited states come in, since the lowest ones determine the path the electron will take under the influence of a perturbation.

Probable patterns of behavior may be inferred from symmetry arguments; however, it is doubtless possible to construct two atomic systems (not necessarily stable) with identical symmetries but different signs of rotation for certain identical dissymmetric environments. For relatively simple systems such as the carbonyl group there are only a few choices which reasonably conform to the known characteristics of the molecule. When one deals with a complex system such as the π electrons in benzene, there are many reasonable choices for the general shapes of states of a given symmetry. These states, which are to be mixed with the low-lying states involved in the transitions under investigation, often themselves have been little investigated experimentally or theoretically.

As a general rule of thumb, it has often been supposed that states which mix with the ground state only play a secondary role in comparison with those which mix with the excited. The success of this assumption depends not so much on the energy differences directly but on the diffuseness of the electron clouds. In general for two given states of an atom the one of higher energy will be more diffuse and will interact more strongly with its environment. If the perturbed ground

(36) *I.e.*, the rotatory parameter varies in the manner indicated.

state preferentially directs charge toward the nearest interacting groups it may happen that this term will predominate. It will not always be a hard and fast rule that the perturbation of the ground state can be neglected.

An examination of a moderately complex chromophore, particularly one of high symmetry, leads to the conclusion that inventing the states needed in optical rotation calculations is at best a marginal proposition. For example, in the benzene chromophore the allowed E_{1u} transition has components of electric moment along the X and Y directions in the plane of the molecule. Perturbation theory requires a state of E_{1g} symmetry for optical activity. Both the valence-bond and molecular-orbital theories give only A_{1g} , A_{2g} , E_{2g} , B_{1u} , B_{2u} , and E_{1u} states for the π -electron system. In molecular-orbital language, the transition takes place from an orbital of E_{1g} symmetry to one of E_{2u} symmetry. The proper linear combination of determinants separates the E_{1u} state from the B_{1u} and B_{2u} states. The functions in question have the form

$$|A_{2u}(1)\overline{A_{2u}}(2)E_{1g}(3)\overline{E_{1g}}(4)E_{1g}'(5)\overline{E_{2u}}(6)|$$

The necessary E_{1g} states must have the form

$$|A_{2u}(1)\overline{A_{2u}}(2)E_{1g}(3)\overline{E_{1g}}(4)E_{1g}'(5)\overline{A_{1g}}(6)|$$

where A_{1g} is any vacant orbital of this symmetry. The ends of optical rotation are best served by those states which allow the introduction of the maximum amount of dissymmetry with the least expenditure of energy. In addition, those states which allow the most charge density near the neighboring groups and have the lowest number of nodes in this vicinity will be highly favorable. Of these requirements the energy requirement is the least stringent, since there is merely an inverse power dependence; however, higher energy states tend to have more nodes, which cause more cancellations in the integrals. It is for this reason that integrals of perturbation functions between states with widely differing quantum numbers tend to zero. It may happen that no one state fully satisfies those requirements.

The most reliable orbital of A_{1g} symmetry is the appropriate σ^* between carbon and hydrogen. There are no carbon-carbon σ^* orbitals of this symmetry. This orbital has two nodes and thereby bears a resemblance to a $3s$ orbital at the center of the ring. The transition in question would be described as π - σ^* . The optical rotatory parameter is determined by matrix elements of the form $\langle E_{2u}|V|\sigma^*A_{1g}\rangle$ (see Figure 12). The σ^* orbital concentrates charge in the plane of the ring and the outermost node leads to a tendency toward cancellation in the matrix element. It would also be desirable to have an orbital which concentrates charge above and below the ring. Here we are pretty much on our own, and the state function we construct will more than likely be one of a set of functions which are properly

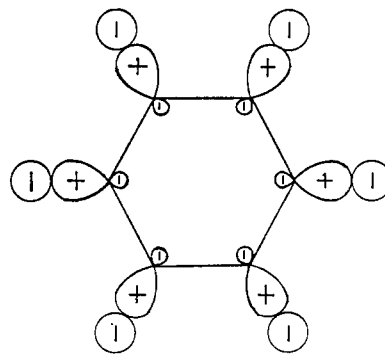

Figure 12.—The A_{1g} σ^* orbital of benzene.

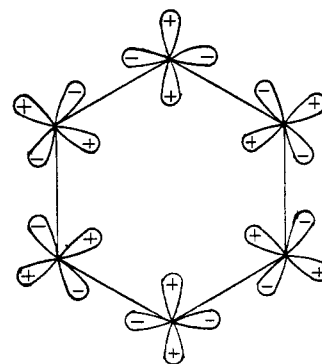

Figure 13.—The A_{1g} $3d_{v^2-z^2}$ function of benzene.

mixed by configuration interaction and not a true state by itself. The $2s$ and $2p$ orbitals having been used, the $3s$, $3p$, and $3d$ orbitals must next be investigated. The $3s$ and $3p$ give nothing in addition to the $2s$ and $2p$ besides more nodes, higher energies, and hence a reduced contribution to the rotation. There are several possible combinations and orientations of $3d$ functions only two of which are linearly independent: $3d_{v^2-z^2}$, $3d_{x^2-y^2}$, $3d_{z^2-r^2}$, the first of which is shown in Figure 13. Even though it would be quite difficult to construct an approximate state function comprised of these orbitals, one may still assert that, so far as their role in perturbations is concerned, the information on these excited states need not be so precise as for the ground and original excited state.

If in the hydrogen-atom problem one were given a complete set of functions identical with the actual solutions except for the exponents, any one of them would in general be inadequate by itself unless the exponent happened to coincide with that of a true state. A variation treatment on the complete set would, of course, set matters aright and introduce the correct combinations. If the original choice had been particularly poor, the convergence would be quite slow, and results of field calculations for various states based on one or two approximate functions would be quite misleading.

If one or two of the lowest states were assumed to be reasonably well known, a set of functions could be formed in a systematic way (*e.g.*, the Schmidt ortho-

normalization procedure) which are orthogonal to each other and to the "known" functions. In the hydrogen example this would lead by a step-wise process to the true functions merely through the requirement that they all be orthogonal to the 1s ground state and to each other. If the average exponent for the E_{1u} state of benzene is known, that for nearest lying excited states may possibly be estimated by this method.

A variation calculation on locally complete (*i.e.*, sets of functions which span various representations of the symmetry group) sets of functions will lead to a new set of functions

$$\psi_j = \sum_{i=1}^N C_i^{(j)} \phi_i$$

$j = 1, \dots, N$, where

$$\sum_{j=1}^N C_i^{(j)} C_{i'}^{(j)} = \delta_{ii'}$$

Even though these new functions will have different energies, there will still be a tendency toward cancellation of cross terms in matrix elements

$$\beta_{ORD} = \langle 0|R|E' \rangle \cdot \langle E'|M|0 \rangle =$$

$$\sum_j \langle 0|R|E \rangle \cdot [\langle E|V|\psi_0 \rangle \langle \psi_j|M|0 \rangle] / -\Delta E_j$$

where E' is the actual excited state and E is the symmetric state of the chromophore. If an average denominator is used, the expression in brackets becomes

$$\sum_{j=1}^N \sum_{i=1}^N \sum_{i'=1}^N C_i^{(j)} C_{i'}^{(j)} \langle E|V|\phi_i \rangle \langle \phi_{i'}|M|0 \rangle = \sum_{i=1}^N \langle E|V|\phi_i \rangle \langle \phi_i|M|0 \rangle$$

Such a method might be expected to give reasonably good results for any terms but coulombic incomplete screening integrals.

F. In view of the great problems in choice of basis functions and rapidity of convergence, an alternative approach which makes maximum use of the known features of the system may be in order. Consider the two terms for the optical rotatory parameter of an electric dipole transition from state 0 to state 1 arising from the perturbation of the ground and excited state

$$\beta_{01} = \langle 0|R|1 \rangle \cdot \left\{ \sum_{i \neq 0} \frac{\langle 1|M|i \rangle \langle i|V|0 \rangle}{E_0 - E_i} + \sum_{j \neq 1} \frac{\langle 1|V|j \rangle \langle j|M|0 \rangle}{E_1 - E_j} \right\} = \frac{\langle 0|R|1 \rangle}{E_0 - E_1} \cdot \left\{ [\langle 1|V|0 \rangle \langle 1|M|1 \rangle - \langle 0|M|0 \rangle] + \sum_{i=2}^N \left[\frac{\langle 1|M|i \rangle \langle i|V|0 \rangle}{E_0 - E_i} + \frac{\langle 1|V|i \rangle \langle i|M|0 \rangle}{E_1 - E_i} \right] \right\}$$

Since the terms $\langle i|V|0 \rangle \rightarrow 0$ with increasing i because of differences in nodes, it should happen that only a handful of true states of the system differing by only a few quantum numbers will make a significant contribution to β_{01} . This being true any tendency toward cancellation will not be unduly stressed by assuming all the denominators to be equal. We can perhaps expect to be little worse off than being forced to construct an incomplete number of excited states whose energies we have no other choice but to set equal.

Subtraction of the $i = 0$ and 1 terms and setting all the denominators equal allows summation over all states and the use of the matrix multiplication rule. The final result is

$$\beta_{01} = \langle 0|R|1 \rangle \cdot \langle 1|V|0 \rangle \left\{ \frac{1}{E_0 - E_1} [\langle 1|M|1 \rangle - \langle 0|M|0 \rangle] + \frac{1}{\Delta E_0} \langle 1|M|1 \rangle + \frac{1}{\Delta E_1} \langle 0|M|0 \rangle \right\} + \langle 0|R|1 \rangle \cdot \left\{ -\frac{1}{\Delta E_0} \langle 1|MV|0 \rangle - \frac{1}{\Delta E_1} \langle 1|VM|0 \rangle \right\}$$

where ΔE_0 and ΔE_1 are positive, and the imaginary part of the expression is to be taken.

In general $MW \neq VM$ and both matrix elements must be evaluated separately. For the magnetic dipole transition the corresponding terms are $\langle 0|RV|1 \rangle = \langle 0|VR|1 \rangle$. For example, in the carbonyl chromophore $\phi_0 = xe^{-ar}$, $\phi_1 = ye^{-a'r}$, and $R = kz$. One is led to the integral

$$e \int xyz V e^{-ar} e^{-a'r} d\tau$$

which is identical in form with the original method without employing the intermediate state. Whatever the shortcomings this calculation places primary emphasis on the detailed properties of the ground and excited states without unduly emphasizing those of an incomplete set of intermediate states.

In view of the great complexity of the optical rotation problem, it is not surprising to find that no one method is particularly satisfactory. One must use the alternative approaches for calculating the same effect as a check on each other. Finally, the use of one- to four-electron model systems of high tractability should provide a feeling for the direction to be taken with actual molecules.

ACKNOWLEDGMENT.—We wish to thank the National Institutes of Health (GM 12862) and the National Science Foundation (Grant GP 3698) for support of this work.